

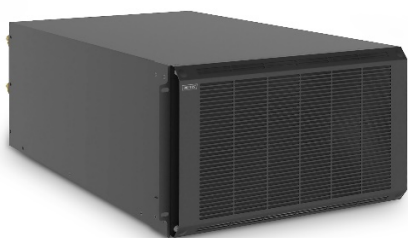

Split Rack Cooling Unit



User Manual

DN-97332 (3.9 kW)

DN-97333 (7.2 kW)

DN-97334 (12 kW)

Table of Contents

1. Security Information.....	3
1.1. Symbol Description.....	3
1.2. Handle Information	4
2. General Information.....	6
2.1. Product Identification.....	6
2.2. Size.....	8
2.3. Environmental Requirements.....	9
3. Installation.....	9
3.1. Installation Preparation.....	9
3.2. Unpacking Inspection	12
3.3. Installation	12
3.3.1. Outdoor Installation	12
3.3.2. Indoor Installation	15
4. Commissioning	16
4.1. Leak, Pressure and Vacuum.....	16
4.2. Add The Amount Of Lubricating Oil.....	17
4.3. Boot Check.....	18
4.4. Run The Debugger	19
4.4.1. Refrigerant Charge Quantity	19
4.4.2. Debugging Content.....	20
5. Maintenance.....	20
5.1. Daily Operations	20
5.2. Common Fault Alarm Phenomenon and Measures	21
6. Control System	25
6.1. Interface Description	25

1. Security Information

1.1. Symbol Description

Installation, operation, or maintenance of equipment before servicing, please read the manual carefully and keep in mind. Other matters on the information in this manual or equipment, the following symbols illustrate messages may appear to warn of potential danger or attention.



Add this symbol indicates that fails to comply with the instructions; there will be a risk of electric shock resulting in injury to persons in the "Danger" or "Warning" safety label.



This is a safety alert symbol used to alert to potential personal injury hazards. Follow all safety information with the symbol, to avoid personal injury or death that may arise.

DANGER ⚠

DANGER indicates an imminently hazardous situation which, if not avoided, will result in death or serious injury.

WARNING ⚠

WARNING indicates a potentially hazardous situation which, if not avoided, can result in death or serious injury.

CAUTION ⚠

CAUTION indicates a potentially hazardous situation which, if not avoided, can result in minor or moderate injury.

NOTICE

NOTICE addresses practices not related to physical injury including certain environmental hazards, potential damage or loss of data.

1.2. Handle Information

Read the handle information before trying to install, operate, service, or maintain it. Comply with local regulation and law when handle refrigerant.

DANGER

Hazard of electric shock, explosion, or arc flash

- Apply appropriate personal protective equipment (PPE) and follow safe electrical work practices.
- This equipment must be installed and serviced by qualified personnel only.
- Turn off all power supplying this equipment before working on or inside the equipment.
- Always use a properly rated voltage sensing device to confirm power is off.
- Replace all devices, doors, and covers before turning on power to this equipment.

Or it can result in death or serious injury.

WARNING

Hazard from moving parts

- Keep hands, clothing, and jewelry away from moving parts. Check the equipment for foreign objects before closing the doors and starting the equipment.

Or it can result in death or serious injury.

CAUTION

Hazard to equipment or personnel

- All work must be performed by qualified personnel.

Or it can result in serious injury or equipment damage.

CAUTION

Hazard of equipment falling over

- Use two or more persons at all times to move or turn this equipment.
- Always push, pull, or turn while facing the front and rear of this equipment. Never push pull, or turn while facing the sides of this equipment.
- Slowly move this equipment across uneven surfaces or door thresholds.
- Lower leveling feet to floor when this equipment is at rest.
- Lower leveling feet and attach joining brackets to adjacent racks when this equipment is in final position.

Or it can result in serious injury or equipment damage.

CAUTION

Hazard to equipment or personnel

- Make sure no spare part or tool in equipment before handle equipment.

Or it can result in serious injury or equipment damage.

CAUTION

Refrigerant high pressure and hazard to equipment

- The equipment is to be charged with R-410A only.
- Copper pipe must support minimum 55 bar pressure.

Or it can result in serious injury or equipment damage.

2. General Information

2.1. Product Identification

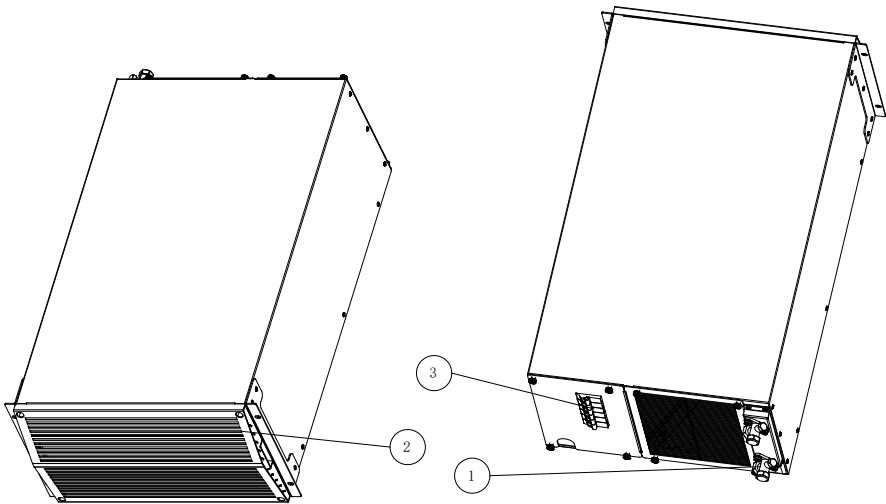

FIG 2-1 3.9 kW/7.2 kW/12 kW exterior view (left side is a front view, right side is a rear view)

1. Shut off valve
2. The front panel
3. Breaker

The compressor - the main role of the refrigeration system through the evaporator for evaporating low pressure refrigerant gas compressed at room temperature to a temperature high-pressure refrigerant gas, increasing its temperature of condensation, into the condenser (outdoor unit) is condensed to a liquid. The key is the core component of the refrigeration system.

High-pressure switch - after the refrigerant pressure in the system rises to a certain value, high-pressure switching operation, the alarm is transmitted to the controller.

High pressure sensor - detecting high side pressure of the refrigeration system, and transmitted to the controller.

Shut-off valve - off device for manual flow conduit connecting pipe (connecting indoor and outdoor) in the refrigerant.

Filter drier - protection refrigeration systems, water filtration systems, solid acid and impurities.

The expansion valve - electronic expansion valve, the refrigerant flow rate regulator.

Evaporator - refrigerant evaporated inside the evaporator absorbs heat, gas flow through the outer surface of the evaporator heat absorber is cooled.

Low pressure sensor - the low-pressure side refrigerant pressure detecting system, and transmitted to the controller.

Low-pressure switch - after the refrigerant pressure in the system decreased to a certain value, low-pressure switch operation, the alarm is transmitted to the controller.

Fan - means for driving an air flow through the air conditioning cycle.

Filter - for filtering dust in the air impurity, individual air-conditioning is standard, fully enclosed mini data center configuration is optional.

Controller - logic control center of the machine, the operation of the automatic control equipment, alarms, details refer to the section controller.

Condensate pumps - When using drainage, not by gravity drainage, the installation of drainage condensate pump, the pump head 10 meters. Pump double float pumps, drainage can be automatically detected, and comes overflow alarm. Pump is an option, when enabled by gravity drainage gravity drainage is recommended.

Overflow switch - when the drain plug, water level reaches a certain height tray overflow switch trigger an alarm, stopping the device operation, to prevent flooding situations.

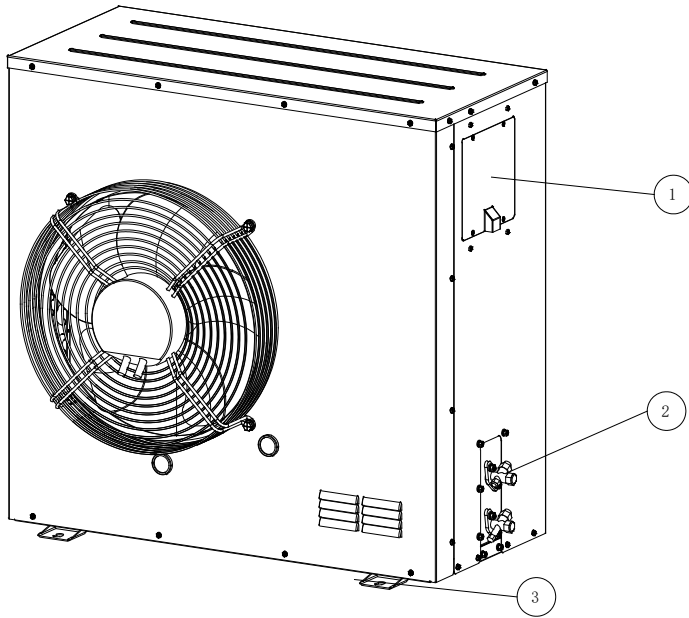

Figure 2-2 3.9 kW/7.2 kW/12 kW view of outdoor unit

1. Connection port
2. Shut off valve
3. Mounting feet

2.2. Size

Table 2-1 Indoor unit size

Product number	Width (mm)	Depth (mm)	Height (mm)
DN-97332	483	686	266
DN-97333	483	686	443
DN-97334	483	686	532

Table 2-2 Outdoor unit size

Product number	Width (mm)	Depth (mm)	Height (mm)
DN-97332	800	395	632
DN-97333	800	420	790
DN-97334	800	420	1240

2.3. Environmental Requirements

Operating Environment

Table 2-3 Products Operating Environment

Project	Indoor side	Outside the room
Temperature	18 °C ~ 40 °C	Air cooled: -20 °C ~ +45 °C
Humidity	20 % to 80 %	-
Altitude	Altitude <1 000 m Greater than 1 000 m Derating about 6 % / one thousand meters	
Power supply	220 ~ 240 V single-phase or three-phase 380 ~ 415 V Frequency 50Hz ± 2Hz or 60Hz ± 2H	

Storage Environment

Table 2-4 Product storage environments

Project	Claim
Surroundings	A clean (no dust), well-ventilated
Temperature	-40 °C ~ +60 °C
Humidity	5 % RH ~ 95 % RH non-condensing
Duration	A total of not more than six months, more than six months to be re-calibrated performance

3. Installation

3.1. Installation Preparation

Tools to prepare

Wrench, socket wrench, Allen wrench, Phillips screwdriver, slotted screwdriver, diagonal pliers, needle nose pliers, the word ladder, tape measure, flashlight, drill, marker. Insulated gloves, wire strippers, insulating tape, hot air gun, crimping pliers. Manual forklifts, electric forklifts, cranes (For lifting). Pressure gauge, pressure pipes, Clamp, antifreeze gloves. Even if the air conditioning is a long tube, you need another tool. Cutter, torch, acetylene, oxygen, welding, nitrogen, pressure relief valve, a vacuum pump, electronic scales.

Material preparation

Brass. Pipe support member, drain line, a power cable. Even if the air conditioning is a long tube, you need the additional material. Brass, cotton insulation of R410A refrigerant, refrigerant oil (also at low temperatures when filling component).

Site Preparation

Indoor: installation location out of the device should be easy, the ground should be able to carry the weight of the carrier device, installation location storey sufficient to install, easy maintenance after the piping arrangement, the circuit arrangement facilitates maintenance, and installation temperature is not too high or too moist security personnel threatening.

Outdoor: smooth out of the wind, away from residential areas. Outdoor wind direction should not be opposite to the monsoon. If direct sunlight, should be done protection. Prevent high temperature and humidity, dust, outdoor air into the acid. Installation position and stay close to the obstacle distance of at least 500 mm. If the outdoor unit installed on the ground, the base to be done cement, the base should be higher than the surrounding ground at least 50 mm, and the base should be larger than the size of the outdoor unit 50 mm.

Installation Guidelines

Equipment must be in good condition. Accordance with the drawings location of the installation and maintenance of equipment before and after more than 900 mm of space left. No short circuit hot and cold airflow, external drainage for antifreeze.

Positive and negative installation value

Table 3-1 Positive and negative installation value

Type	Vertical height value	Others
Positive	Max: +20m	Indoor unit lower than outdoor unit
Negative	Max: -5m	Indoor unit higher than outdoor unit

1. Should install reserve banding in the intake pipe and drainage pipe of outdoor unit when installation, to avoid liquid backflow when power off.

2. If positive gap is bigger than 20 m or connecting pipe is longer than 30 m. Extension component is needed.
3. Install oil bending in every 6 m vertical height of gas pipe when the installation vertical height is over 10 m.
4. Liquid pipe shall not be under the sunlight directly. Heat insulation is needed.
5. The gas pipe and condensate drain of indoor unit shall piping with particular angel (exhaust pipe angle $\geq 0.3^\circ$).
6. When installed in negative gap, condenser liquid pipe shall piping with particular angel (gas pipe angle $\geq 0.3^\circ$)

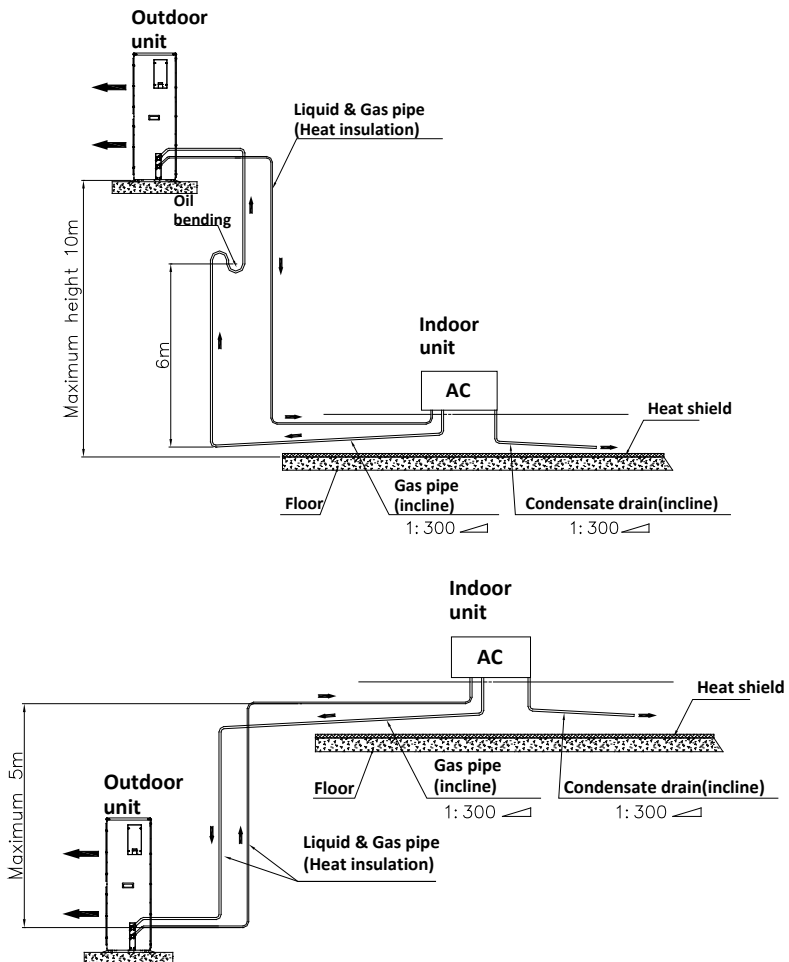

Figure 3-1 Rack mounted cooling positive and negative installation instruction

3.2. Unpacking Inspection

Out of the box before check the packaging for damage, if there is damage, please contact the carrier.

Carefully remove the packaging and check whether there are internal devices scratches, impact, if any, please contact the carrier.

The packing list an inventory of accessories are complete, if not complete, please contact the supplier.

After removing the desiccant check whether the needle has a needle cap, a short press will remove the valve needle cap, whether gas emissions, if not, contact the supplier. If so, then the needle cap to re-install the good.

3.3. Installation

3.3.1. Outdoor Installation

Installation DN-97332/DN-97333/DN-97334

1. The outdoor unit placed on the base.
2. The outdoor unit expansion bolts fixed to the base.

Piping Installation

Piping principle

1. The use of copper pipe connection between the indoor unit and outdoor unit, 3.9 kW/7.2 kW/12 kW which an indoor unit and an outdoor unit are imperial quick connector nipple (when the pipe length exceeds standard pipe length requires the use of welding connections the brass);
2. SmoothAir refrigerant air conditioning units as standard is R410A. 3kW/7kW/12kW refrigerant factory prefilled.
3. All refrigerant pipe should be as short as possible and beautiful, neat, smooth vertical and horizontal, to minimize the elbow, fixed.
4. Comply with industry standard selection Pipe Size, Pipe size recommended values refer to Table 3-2.
5. Between the evaporator and the condenser recommended maximum distance of 30m (equivalent length), If the distance exceeds this, please contact the manufacturer for help. Equivalent length of the sub-assembly is shown in Table 3-3.

Table 3-2 Pipe size recommended

Model	Tube length (equivalent)					
	10 m		20 m		30 m	
	ØD (mm)	ØL (mm)	ØD (mm)	ØL (mm)	ØD (mm)	ØL (mm)
DN-97332	13	10	13	10	13	10
DN-97333	13	10	13	10	13	10
DN-97334	16	13	16	13	19	13

Table 3-3 Equivalent length of the sub-assembly

Fluid tube diameter (mm)	Equivalent length (m)		
	Elbow 90°	Elbow 45°	T-piece
10	0.21	0.10	0.76
13	0.24	0.12	0.76
16	0.27	0.15	0.76
19	0.30	0.18	0.76
22	0.44	0.24	1.1
28	0.56	0.30	1.4

Be careful when installing quick nipple before operation, please read the following precautions.

1. Remove the dust cover of the valve connector.
2. Carefully wipe with a clean cloth and the connecting base flanks.
3. Refrigerating oil lubricated surface mating connector.
4. The coupling nut screwed onto a threaded joint and ensure positive fit.
5. The hex nut and connected to a valve body fastened until significant resistance until the felt.
6. Strokes with oil from a longitudinal line connecting the nut to the ferrule; then two wrenches to tighten the nut with a quarter-turn in order to ensure airtightness. Crossed dislocation has shown that tight junctions. The installation process must use two wrench engagement

operation, the operation of a spanner easily because damage to the copper tube connected to the valve.

Note refrigerant line connected to

1. Manufacturers provide 3.9 kW/7.2 kW/12 kW 5 m standard pipe, such as pipes require a longer, contact with the sales staff.
2. The liquid return pipe diameter should be selected and reasonable length, to ensure that the pressure drop of the refrigerant liquid flows through the tube unit operation generated no more than 40kPa. Unit and the exhaust pipe and return pipe insulation were to be processed.
3. The installation and removal of the refrigerant pipe should be careful, so that the line will not distort or damage.
4. All refrigerant pipe connection as by welding, use of silver braze welding electrode. During the welding process, should pass the 0.03MPa Nitrogen protected.
5. When the pipeline and welding the ball valve, it should pack a damp cloth to cool ball to prevent heat damage.
6. The refrigerant tube support is arranged to be set up before completion of the pipe, using the refrigerant pipe between the control card and the support frame, the fixed connection pipe collar to avoid direct contact.
7. The refrigerant pipe passes through the wall or other obstacles to be avoided by measures such as brass cushion in direct contact with the wall, in order to avoid damage to the tubing, while reducing the vibration.
8. Horizontal pipeline slope should meet the design requirements. They in unit oil return.
9. When the outdoor unit is installed above the indoor unit 6 m, the gas pipe should be installed side-trap.
10. The refrigerant line before use, should leak, pressure and vacuum test, and the vibration insulating spacer frame spaced from the refrigerant line and the building.

3.3.2. Indoor Installation

Mechanical Installation

Install rack mounted cooling unit in the rack.

Sewer Installation

Drain pipe is 20mm, drainage pipes and fittings with the room air conditioning drain access the drainage system.

When installing sewer, note the following requirements:

1. The drain is not directly exposed to the temperature is below 0 °C.
2. When installing sewer pipe diameter and strictly ensure the slope;
3. Do water in the drainage test, requiring drainage flow, drainage installation trap;

Electrical Installation

When electrical installation, note the following requirements:

1. All power cord, connect the control line and ground must comply with local regulations.
2. A full load operating current of the unit, check the unit nameplate. Cable size should meet the electrical requirements.
3. The need to connect a cable is indoor power line, the power line of the outdoor unit.
4. Main power supply unit requires the same rated power and the nameplate.
5. The cable can be selected only copper cable, wiring to ensure that all connections are secure.
6. The electrical installation must be done by a professional electrical installer.
7. Before connecting circuit, an input power source voltage, and the power supply has been disconnected is determined with a multimeter.

After completion of the electrical installation, you need to check the following:

1. Same rated supply voltage and the voltage on the rating plate.
2. The crew did not open electrical circuit, short circuit.
3. The circuit breaker connecting the indoor unit and the outdoor unit of the power and ground wires are connected.

4. The power supply circuit breaker and fuse rating to meet the needs of the unit.
5. If the monitoring cable, check the monitor cable is connected.
6. Check all cables, connectors have been tightened, without loosening the fixing screws.

4. Commissioning

4.1. Leak, Pressure and Vacuum

1. After completion of all pipe connections, with a nitrogen leak pressure test, the inflation pressure should $\geq 3\text{MPa}$, and from the high and low pressure portion while charged with nitrogen until equilibrium is.
2. After purged with nitrogen, 24 hours dwell time should be no leakage, such as large temperature changes within 24 hours, since the thermal expansion characteristics of the gas, there will be slight changes in pressure, such as the temperature difference is 3°C , Pressure changes $\leq 1\%$, should be normal, if the pressure change value is exceeded, then the leak should be found to re-welding pressure test.
3. After completion of leak, let go of the nitrogen gas in the system, the vacuum pump to evacuate the system. After the system is evacuated to an absolute vacuum of 100Pa , Paul negative 2h, if the pressure does not rise then it is qualified.

Note

1. $3\text{kW}/5\text{kW}/7\text{kW}/12\text{kW}$ prefilled without refrigerant.
2. prohibited the use of oxygen or other gas tightness test.
3. the system leak charged nitrogen pressure plate unit cannot exceed the nominal maximum working pressure. Even an increase of the refrigerant pipe length.

If the connecting line between the indoor unit and the outdoor unit over a certain distance needs to be added to the system to the refrigerant system operation.

The addition amount of the refrigerant can be calculated according to the following formula:

The addition amount of the refrigerant (kg) = Control unit length was added in an amount of refrigerant (kg / m) × the total length of the liquid extension pipe (m)

3.9 kW/7.2 kW/12 kW extend the overall length was set (m) = Total length of catheter -5m (m); Control unit length of the liquid refrigerant amount is added, as shown in Table 4-1.

Table 4-1 The addition amount of different diameters per unit length of the liquid refrigerant

Liquid pipe diameter (mm)	Unit length the addition amount of the refrigerant (kg/m)
9.52	0.060
12.7	0.112
16	0.181
19	0.261
22	0.362
28	0.618

4.2. Add The Amount Of Lubricating Oil

When the union sufficiently long, the compressor discharge air along with the lubricating oil adhered to the wall and the mixing amount of the refrigerant in the oil return loop effect, we have added to the refrigeration system lubricant, to ensure compressors normal, efficient operation.

In general, even the tube length cannot be added within 30m lubricant. Unit amount of the lubricant added is calculated by the following formula:

The formula is:

$$L = \frac{(R - M) \times 0.4}{0.9} \times 1000$$

Wherein: L - amount of lubricating oil needs to be added (ml)

R - System adds the amount of refrigerant (kg)

M - Conditioning allowable maximum charge amount (kg)

Table 4-2 Air conditioning allows maximum charge amount

Model	The maximum allowed amount of charge – kg
DN-97332	2
DN-97333	2
DN-97334	2

Note:

SmoothAir precision air conditioning uses R410A environmentally friendly refrigerant compressor lubricants in strict accordance provide models to buy. The refrigerant R410A be added RL68H (or the other makes the same viscosity) synthetic oils.

4.3. Boot Check

Before the unit turn on, for each member state of the inspection system in Table 4-3.

Table 4-3 Check before starting the unit

Project	Check the contents and requirements
The whole appearance	No damage to the appearance, clean surface, intact insulation
Filter	Filter should be installed in place, clean appearance, no damage
Power supply	It should be no loose power wiring, power unit before transmission, measure and record the voltage value
Electrical control box	Electric wiring electrical component box firmly, without loosening
Indoor fan	Into the wind, the wind barrier no block
Valve	All valves should be in the open state
The outdoor unit	Outdoor installation suitable location; reasonable installation

	of pipelines; oil unbending installed in the correct position
Heater	Securely mounted electric heater
Humidifier	To the sewer connection in place, the wiring is correct. If no configuration is ignored.

After checking the above items before power supply to the unit operation. After the unit power operation, Table 4-4 items to be checked.

Table 4-4 After checking the boot project

Project	Check the contents and requirements
Indoor fan	The fan rotation is correct; the fan operating current record
Compressor	Compressor rotation is correct; recording its operating voltage, current
Fan speed controller	Recording speed controller output voltage
Heater	Heater current record
Humidifier	Humidifier recording current, voltage
Pressure	Recording the discharge pressure, suction pressure, the liquid valve before the pressure
Temperature	Recording user set valve; unit return air temperature and outlet air temperature

4.4. Run The Debugger

4.4.1. Refrigerant Charge Quantity

Depending on design parameters of the unit (the degree of subcooling, the degree of superheat, the intake / exhaust pressure, etc.), charge injection unit of the refrigerant is calibrated to run, so that the amount of refrigerant charge reaching requirements.

4.4.2. Debugging Content

- a) Measuring and recording operating parameters of the unit (return air temperature, air temperature, the liquid pipe pressure, intake pressure, temperature of the valve before the intake air temperature);
- b) Adjusting the operating parameters of the compressor (the compressor suction, discharge pressure control in a suitable range, and adjust the degree of superheat and subcooling to a suitable value);
- c) Running the debug electrode humidifier (humidifier operating current measurement), if no configuration is ignored;
- d) Running the debug electric heater (heater operating current measurement).

[Note: Start-up operation by professional engineers to complete.]

5. Maintenance

5.1. Daily Operations

In the daily management of the engine room, the air conditioning for precision management and maintenance mainly refrigeration systems, fans, air filters, humidifiers, heaters, drainage and so on. The adequacy of daily operations management, stable operation of the unit will, life and energy savings has a significant impact, and please users strictly enforce the daily management of precision air conditioning.

Table 5-1 Daily operations project

Project	Content
Tour	Check that the air conditioning system in normal operation
	Various functions and parameters are normal, if an alarm situation to check the alarm log, and analyze the cause of the alarm
Ventilation system	Check the Fan If abnormal noise
	Check that the motor current is normal

Cooling System	Suction pressure and discharge pressure is normal
	Confirmed that the amount of refrigerant charge is appropriate
	Whether the refrigerant leakage phenomenon
	See color sight glass
	Drain water tray is smooth
	If there is frost expansion valve
	Whether the compressor frost occurs
	Whether evaporator frost occurs
	Line for damage
	Pipe insulation is normal
Other	Without loosening under examination terminal head
	Check off whether the screws drop phenomenon
	Check whether the supply voltage in the normal range
	Check the floor below normal situation
	Check if the indoor unit loosening

5.2. Common Fault Alarm Phenomenon and Measures

Failure mainly for the precision air conditioning units cooling system failure, control system failure, the ventilation system failures and communications failures, some of Common symptoms and treatment recommendations Table 5-2 Common alarm phenomenon and measures.

Table 5-2 Common Fault Alarm Phenomenon and Measures

Symptom	Possible Causes	Responses
The unit does not start	The unit is not powered on	Check the input power supply apparatus, the wiring is solid
	Power sequence is wrong	Check the phase sequence power and wiring
Compressor overload	Thermal overload	Check the air conditioning Refrigerated space Insulation and sealing the case, the necessary Time Plus equipment

	Excessive refrigerant system	Excess refrigerant discharged within the system
	Compressor own fault	Compressor axle, the motor coil insulation in question must be replaced compressor
	Supply Voltage Value	Negative power supply voltage instability factor
	Compressor loose wiring	Good re-tighten the compressor terminal
High pressure protection alarm	Pressure protection switch fault	Replace the pressure protection switch
	Expansion valve is too loose,	Appropriately adjusting the opening degree of the expansion valve
	The expansion valve bulb failure or incorrect mounting position	An expansion valve replacement, and proper installation position bulb
	Summer too much refrigerant perfusion	Remove excess refrigerant, the high pressure in the control 2.3~2 Between .8Mpa
	Outdoor condenser fouling	Cleaning the surface of dust and dirt condenser
	Axial fan does not turn	Check axial fan static resistance and the grounding resistance, such as fan coil burning should be replaced;
	Systems non-condensable gases mixed with	Height from the system gas discharge portion, the system re-evacuated if necessary, charge fluoride work
Fan overload	Airflow is too large	Check the filter installation, whether to select an error windshield

	Voltage is too low	Check input power
	Fan motor winding fault	Check whether the motor windings normal
Low-pressure protection alarm	Low Voltage Protection Switch Fault	Replace the low protection switch
	Expansion valve is too small	Appropriately adjusting the opening degree of the expansion valve
	The expansion valve bulb failure or incorrect mounting position	An expansion valve replacement, and proper installation position bulb
	Lack of refrigerant in the system	Tim refrigerant charge control in the low voltage 0.9~1 Between Mpa
	Filter clogging dried	Replacing the filter was dried
	Evaporator frosting	Respond to the evaporator to defrost
	Evaporator surface fouling	Cleaning of the evaporator evaporation surface
	Air volume is too small	Check that the air filter is clogged and a return air conduit
	Low-voltage protection delay is not set correctly	Readjustment of the low-pressure time delay
High temperature alarm	The upper temperature limit is unreasonable	Reset
	Unit Load Design is too small	An examination refrigerated space sealing the case, if necessary, additional equipment

	Refrigeration system is not turned on	Check the cooling system work
Low temperature alarm	Temperature limit is unreasonable	Reset
	Site irregularities	Winter examination room sealed situation, the venue for unusual circumstances
	No high-humidity heat load	Increased thermal load
Low humidity alarm	Humidity limit set unreasonable	Reset
	Device is not configured humidifier	Optional humidifier if necessary, please
Humidity alarm	Humidity upper limit is unreasonable	Reset
	Room without making moisture-proof measures	To be moisture treatment room

6. Control System

6.1. Interface Description

The program interface is divided into homepage, menu page, and alarm page.

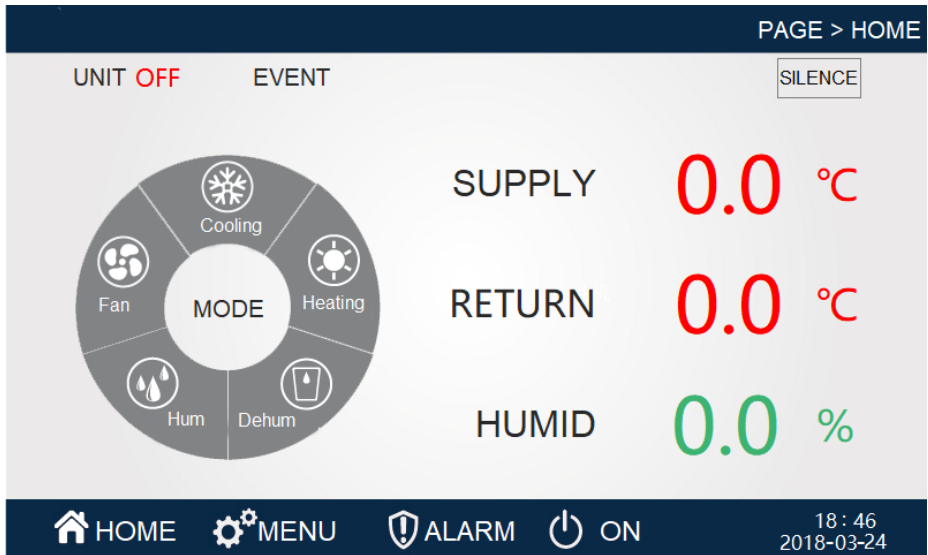

Figure 6-1 Home

Automatically enter the home page when you are on power. Or automatically return to the home page if the interface is not operated for a long time.

(21:10/2018-03-24) Time/date: show current date, You can change the time in the clock Settings.

(Home/menu/alarm/boot) Menu options: click the corresponding option to enter the corresponding menu page.

The "**home page**" option currently displays the embedded background mode, representing the current page as the home page. Other pages are similar, and the post is not repeated.

(Temperature 0.0 °C) shows that temperature sensors to detect real-time temperature.

(Humidity 0.0 %) shows the real-time humidity detected by humidity sensor.

(The unit state shutdown) shows the current operating state of the unit and the "boot" state.

(Alarm) This will scroll to show all the current alarms.

(Censored) When there is an alarm, there will be a warning sound, click the noise to eliminate the alarm sound.

(Operating state refrigeration and heat dehumidification humidifier) various functional operation status.

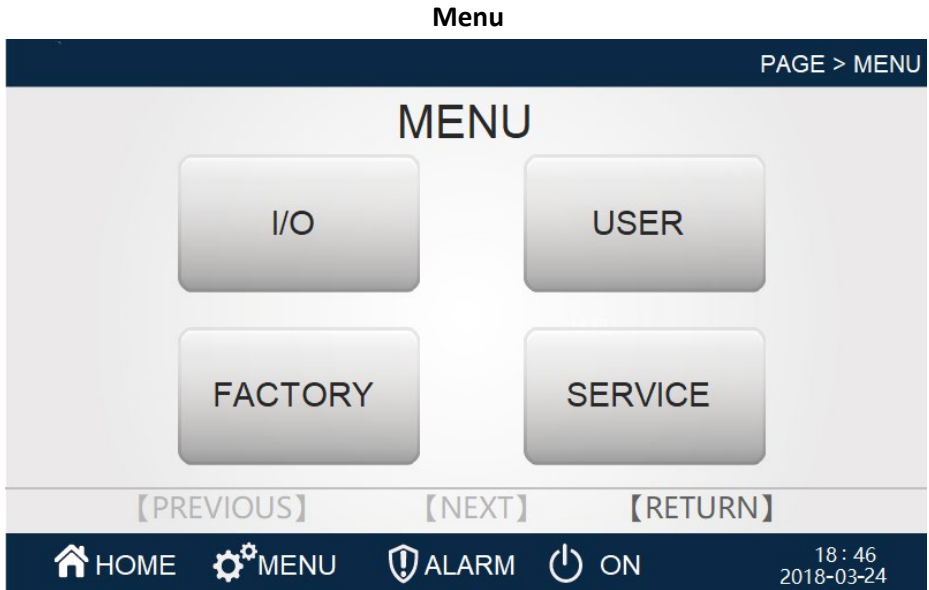

Figure 6-2 Menu

You can enter the menu page at other page point menu.

(I/O) Click to enter the input output page, including all digital input output information and analog quantity input and output information.

(User Settings) click to enter the user Settings page, including the parameters set by the user.

(Factory Settings) click to enter the factory Settings page, including all factory Settings.

(Maintenance Settings) click to enter the maintenance Settings page, including all maintenance Settings parameters.

Alarm

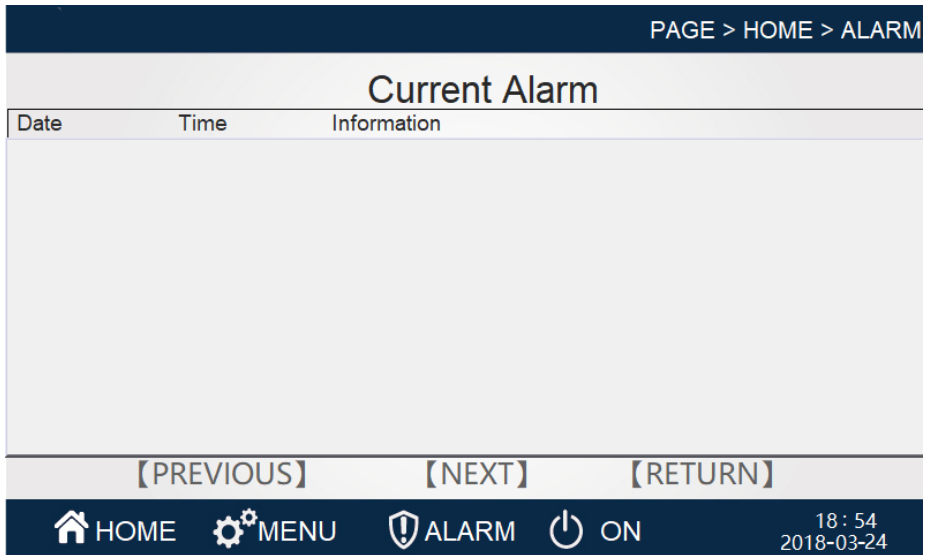

Figure 6-3 Current alarm

Under this menu, you can view all alarms that exist in the current unit.

(Trigger date) the exact date of the alarm.

(Trigger time) The timing of the alarm.

(Alarm content) Warning.

(Return) The return key is returned to the previous page.

(Next page) Page turn option, click to enter the history alarm page.

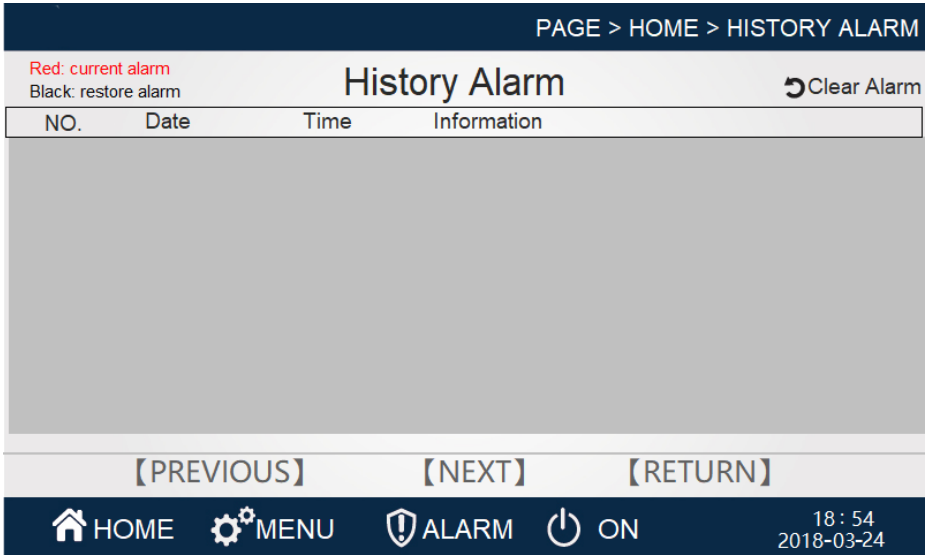

Figure 6-4 History alarm

Under this menu, you can view all the uncleared alarms that have occurred before the current crew.

(serial number) Alarm number.

(date) The exact date of the alarm.

(time) The timing of the alarm.

(alarm content) Alarm content.

(return) The return key is returned to the previous page.

(next page) Page turn option, click to enter the current alarm page.

(clearance alarm) Click to clear all history alarms.

Input/Output 1

PAGE > MENU > I/O 1

The screenshot displays the 'Input/Output 1' menu. At the top, it shows the navigation path 'PAGE > MENU > I/O 1'. The main content is divided into two sections: 'Device Output State' and 'Port Input State'. The 'Device Output State' section lists five items: ID Fan, Heater, Humidifier, Fix Compressor, and Lee Valve, each with a play button icon and the text 'OFF'. The 'Port Input State' section lists three items: Water Leakage/Over Alarm, HP/HD Switch, Heater Alarm, and Filter Maintenance, each with a blue play button icon and the text 'Close'. Below these sections are three navigation buttons: '【PREVIOUS】', '【NEXT】', and '【RETURN】'. At the bottom, there is a dark blue navigation bar with icons for HOME, MENU, ALARM, and ON, along with the time '18:47' and date '2018-03-24'.

Device Output State					
ID Fan	▶	OFF	Fix Compressor	▶	OFF
Heater	▶	OFF	Lee Valve	▶	OFF
Humidifier	▶	OFF	Bypass Valve	▶	OFF

Port Input State					
Water Leakage/Over Alarm	▶	Close	Heater Alarm	▶	Close
HP/HD Switch	▶	Close	Filter Maintenance	▶	Close

Figure 6-5 Input/output1

Under this menu, you can view the current unit number input state and digital output status. When the output status of the device is blue, the device is in the output state and the device is in a non-output state when the color is gray. When the port input state is blue, the port is entered into a closed state, and when the color is gray, the device is disconnected.

(return) The return key is returned to the previous page.

(next page) Page turn option, click to enter the input output 2 page.

Input/Output 2

PAGE > MENU > I/O 2





SENSOR DATA					
HP Pres	0.0	bar	Humidity	0.0	%
LP Pres	0.0	bar	Return Temp	0.0	°C
Suction Temp	0.0	°C	Supply Temp	0.0	°C
ID Fan Speed	0	%	OD Fan Speed	0	%
Comp Freq	0	Hz	Evap Temp	0.0	°C
Superheat	0.0	K	Liquid Pipe Temp	0.0	°C
Subcooling	0.0	K	Cond Temp	0.0	°C
EEV Step	0	step			
【PREVIOUS】		【NEXT】		【RETURN】	
 HOME	 MENU	 ALARM	 ON	18:47 2018-03-24	

Figure 6-6 Input/output1

Under this menu, you can view the current unit simulation input and output values.

(temperature and humidity curve) Click to enter the temperature and humidity curve interface.

(pressure curve) Click into the pressure curve interface.

(return) The return key is returned to the previous page.

(previous page) Turn page option, click to enter the input output 1 page.

Temperature humidity curve

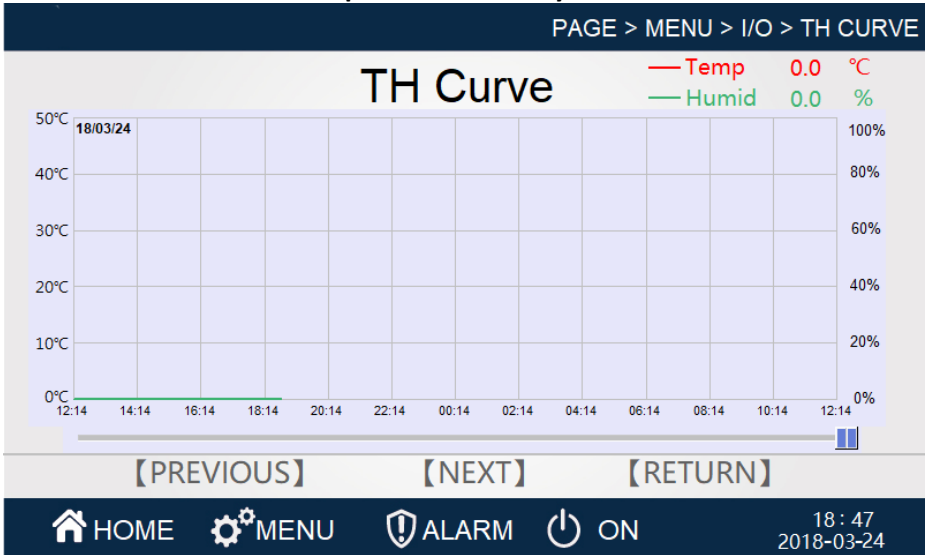

Figure 6-7 temperature humidity curve

Pressure curve

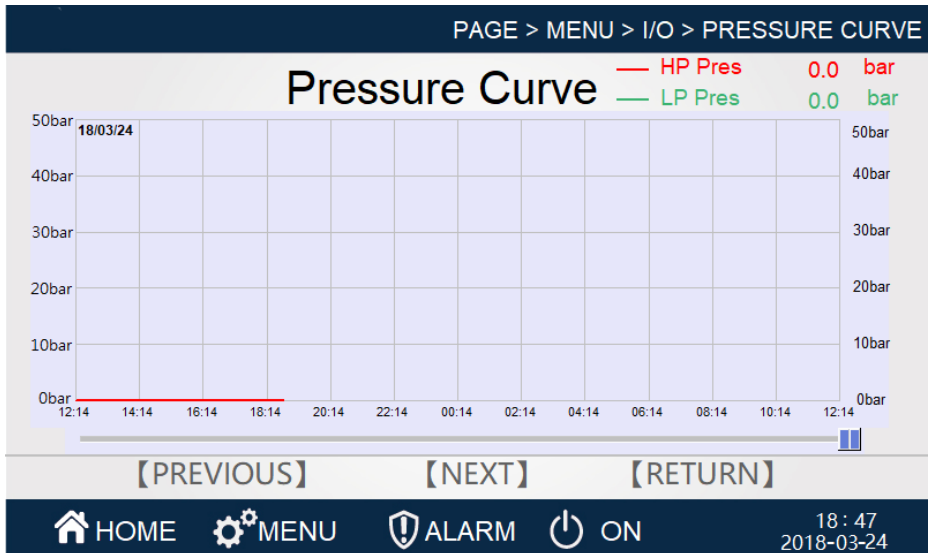

Figure 6-8 pressure curve

User Settings

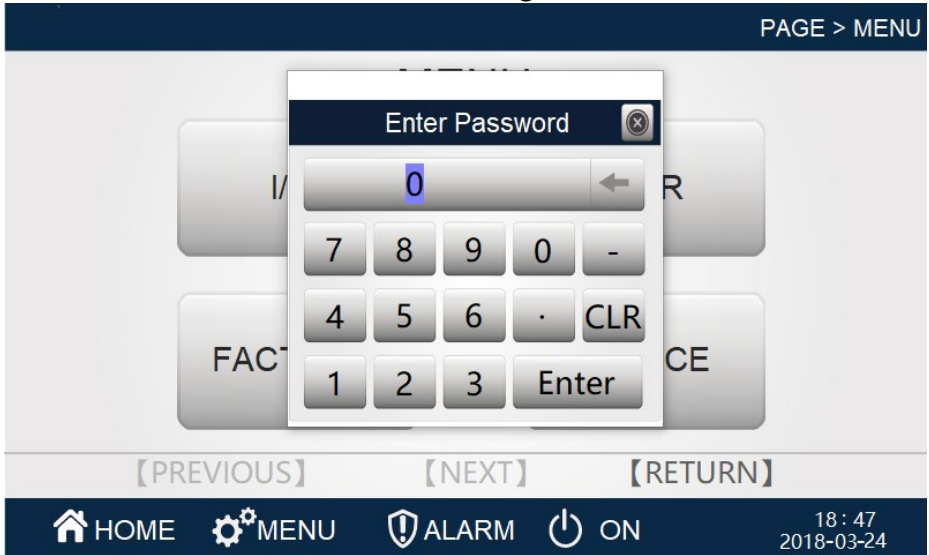

Figure 6-9 Enter password

Enter password “4321” Enter the Settings page.

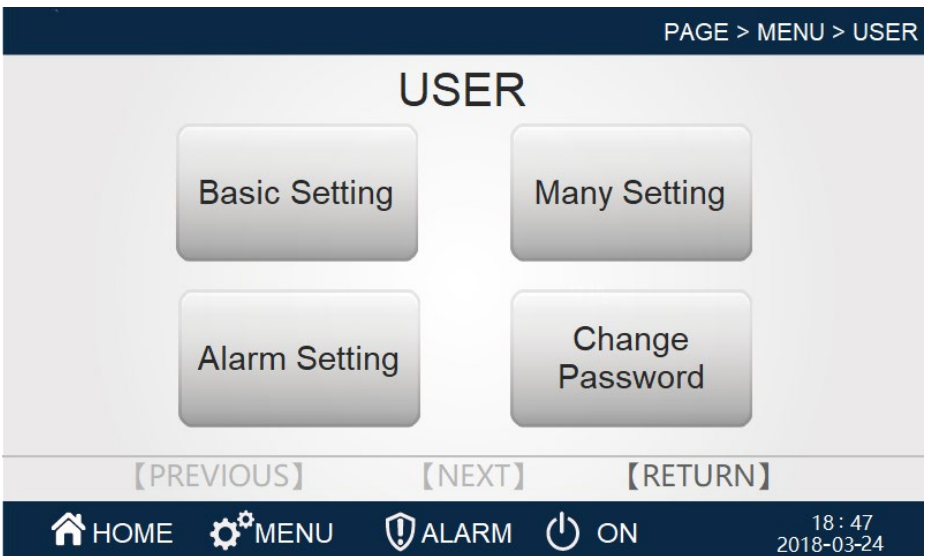

Figure 6-10 User

Click the user Settings option on other page points to enter the user Settings page.

(Basic setting) Click to enter the basic Settings page, including temperature and humidity Settings.

(Many setting) Click to enter the comprehensive Settings page, including date time, monitoring address, etc.

(Alarm setting) Click to enter the alarm Settings page, including alarm value Settings, alarm property Settings.

(Change password) Click to enter the change password page and change the user password.





Basic Setting

PAGE > MENU > USER > BASIC SETTING

Basic Setting

Temp Setting	<input type="text" value="0.0"/>	°C	Humid Setting	<input type="text" value="0.0"/>	%
Temp Band	<input type="text" value="0.0"/>	°C	Humid Band	<input type="text" value="0.0"/>	%
Dehum Limit Temp	<input type="text" value="0.0"/>	°C	Recom Humid St	<input type="text" value="0.0"/>	%
Heat ON Band	<input type="text" value="0.0"/>	°C	Heat OFF Band	<input type="text" value="0.0"/>	°C
Control Mode	<input type="text" value="Supply Air"/>		Humid Control Mode	<input type="text" value="AH Control"/>	
			Humid Control Valve	<input type="text" value="0.0"/>	%

[PREVIOUS] [NEXT] [RETURN]

 HOME  MENU  ALARM  ON

18 : 47
2018-03-24

Figure 6-11 Basic setting

(Temp Setting 0.0 °C) Set the temperature setting value, that is, the expected indoor temperature.

(Humid Setting 0.0 %) Set the humidity setting value, that is, the expected indoor humidity.

(Temp Band 0.0 °C) Set the temperature range, that is, the deviation of the set point of the temperature, to ensure that there is a deviation in the temperature point of the device starting and stopping, and it will not stop frequently during the partial load. Set temperature ranges compatible with frequent start-stop and allowable temperature fluctuations.

(Humid Band 0.0 %) Set the humidity range, that is, the deviation of the humidity set point, to ensure that there is a deviation between the starting and stopping humidity point of the equipment, and it will not stop frequently during the partial load. When setting the humidity range, it is compatible with frequent start-stop and allowable humidity fluctuations.

(Heat on band 0.0 °C) Set the heating opening deviation, that is to achieve the temperature deviation after the basic conditions of heating.

(Heat off band 0.0 °C) Set the heat closing deviation, that is, to meet the basic conditions of thermal shutdown after the temperature deviation.

(Control mode return air) The temperature control is based on the risk control system, and the air supply can be selected.

(repower startup) Turn on the incoming call function.

(return) The return key is returned to the previous page.

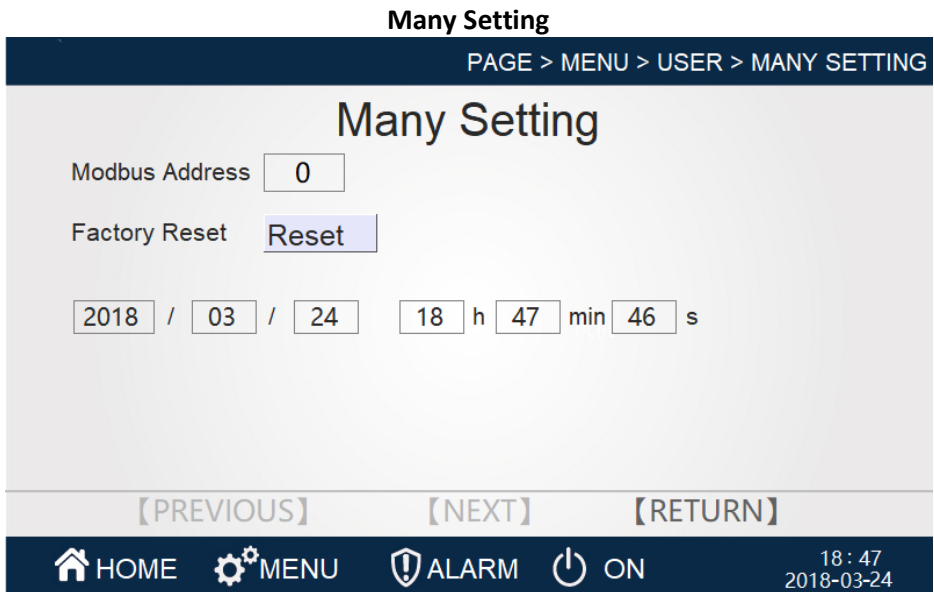

Figure 6-12 Many Setting

(2018 Year 03 month 20 day 13 hour 22 minute 52 second) Date and time, you can set the current date and time.

(Modbus address 0) Monitor address, you can set the monitor address of the controller.

(restore factory reset) Factory setting reset.

(return) The return key is returned to the previous page.

Alarm Setting

PAGE > MENU > USER > ALARM SETTING

Alarm Setting

High Temp Alarm Band °C High Humid Alarm Band %
Low Temp Alarm Band °C Low Humid Alarm Band %

【PREVIOUS】

【NEXT】

【RETURN】



HOME



MENU



ALARM



ON

18 : 47
2018-03-24

Figure 6-13 Alarm Setting

(High temperature alarm 0.0 °C) High temperature alarm value, the return air temperature exceeds the high temperature alarm set value and then the alarm. Click the number to set.

(Low temperature alarm 0.0 °C) Low temperature alarm value, the return air temperature is lower than the low temperature alarm set value and then the alarm. Click the number to set.

(high humidity alarm value 0.0%) The high humidity alarm value, the return air humidity exceeds the high humidity alarm set value after the alarm. Click the number to set.

(low humidity alarm value 0.0%) The low humidity alarm value, the return air humidity is lower than the low wet alarm set value after the alarm. Click the number to set.

(return) The return key is returned to the previous page.

User Change Password

PAGE > MENU > USER > CHANGE PASSWORD

Change Password

User Password

【PREVIOUS】 【NEXT】 【RETURN】

HOME MENU ALARM ON 18:48
2018-03-24

Figure 6-14 User change password

(user password Settings*****) click the text box to change the password.

User password confirmation

PAGE > MENU > USER > CHANGE PASSWORD

Change Password

User Password

Operation Confirm

【PREVIOUS】 【NEXT】 【RETURN】

HOME MENU ALARM ON 18:48
2018-03-24

Figure 6-15 User password confirmation

(password confirmation) can be changed after entering the new password.

Hereby Assmann Electronic GmbH, declares that the Declaration of Conformity is part of the shipping content. If the Declaration of Conformity is missing, you can request it by post under the below mentioned manufacturer address.

www.assmann.com

Assmann Electronic GmbH

Auf dem Schüffel 3

58513 Lüdenscheid

Germany

